



Características Técnicas
Technical Data

Três Modelos de Corpo da Tocha - Three Models of Torch Bodies
Cordoalha Estanhada - Tinned Conductor
Corpo Interior sem Solda - Body Made in a Single Part, Without Any Weld
Menos Aquecimento - Less Heat
Maior Passagem de Corrente - Improved Conductivity

Indicações
Recommendation

Serviços Médios
Medium Works

Catálogo Digital
QR Code



Corrente - Current



1,0 - 3,17

Eletrodo (mm)
Electrode (mm)

Weld 26

Código/Code	Descr./Descr.	Corpo/Body	Tipo/Type	Engate/Coupling	Med./Mes.
0610.0001				Convencional Standard	
0610.0017	Tocha de Solda TIG SU26 SU26 TIG Welding Torch	Silicone Silicon	Registro Valve	Engate Rápido Fast Coupling	9,00mm
0610.0016					12,80mm

Tocha/Torch TIG Weld 26

Código/Code	Descr./Descr.	Corpo/Body	Tipo/Type	Engate/Coupling	Med./Mes.
0610.0014				Convencional Standard	
0610.0018	Tocha de Solda TIG SU26 SU26 TIG Welding Torch	Silicone Silicon	Acionamento Trigger	Engate Rápido Fast Coupling	9,00mm
0610.0012					12,80mm

Tocha/Torch TIG Weld 26

Foto/Photo	Pos.	Código/Code	Descrição/Description	Med./Mes.
	01	0600.2119	Bocal de Cerâmica Alumina Nozzle	n° 04 ø6,5mm
		0600.2120		n° 05 ø8mm
		0600.2121		n° 06 ø9,5mm
		0600.2122		n° 07 ø11mm
		0600.2123		n° 08 ø12,5mm
		0600.2124		n° 10 ø16mm
	02	0600.2027	Corpo Fixador Collet Body	1,59mm 1/16"
		0600.2028		2,38mm 3/32"
		0600.2029		3,17mm 1/8"
	03	0600.1036	Anel Inferior Bottom Cup Gasket	

Foto/Photo	Pos.	Código/Code	Descrição/Description	Med./Mes.
	04	0610.0003	Corpo da Tocha Silicone Silicon Torch Body	p/uso de Registro w/Valve
	05	0600.1385	Corpo da Tocha Silicone Silicon Torch Body	p/uso de Acionamento for Trigger

**CORPO PARA
USO DE REGISTRO**
Torch Body for Valve Use



**CORPO PARA
USO DE ACIONAMENTO**
Torch Body for Trigger Use

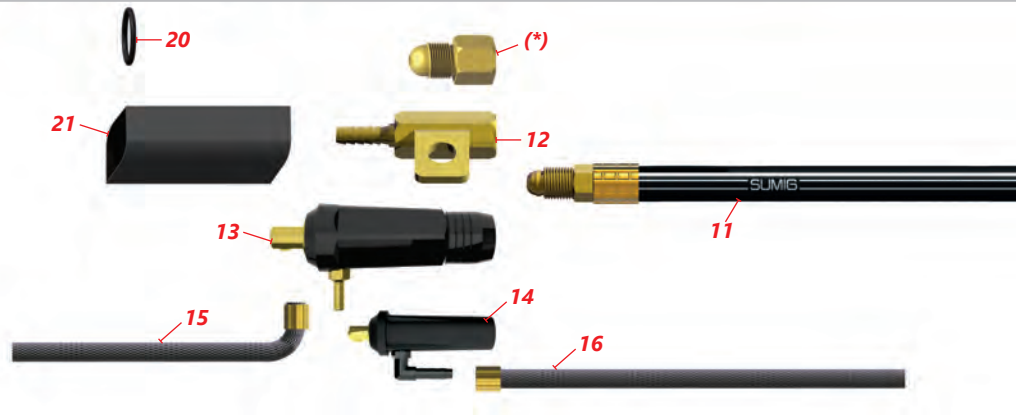
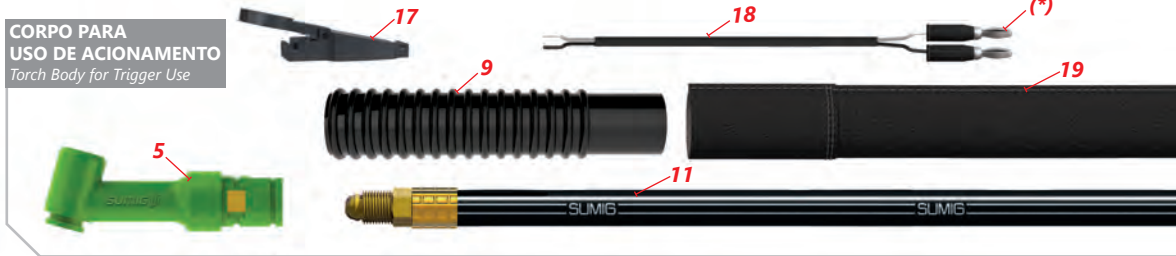

(*) Linha de Opcionais/Optional Line

Foto/Photo	Pos.	Código/Code	Descrição/Description	Med./Mes.
	06	0600.1043	Fixador Collet	1,00mm
		0600.2030		1,59mm 1/16"
		0600.1045		2,00mm 5/64"
		0600.2031		2,38mm 3/32"
		0600.2032		3,17mm 1/8"
	07	0600.2025	Capa Curta Short Cap	
	08	0600.2026	Capa Longa Long Cap	
	09	0600.2035	Punho da Tocha Torch Handle	
	10	0600.1054	Registro do Corpo Torch Valve	
	11	0610.0006	Cabo de Gás e Força p/Sistema Engate Rápido 9,00mm Gas-Power Cable for Standard System and 9,00mm Fast Coupling	
		0610.0000	Cabo de Gás e Força p/Sistema Convencional e Engate Rápido 12,80mm Gas-Power Cable for Standard System and 12,80mm Fast Coupling	

Foto/Photo	Pos.	Código/Code	Descrição/Description	Med./Mes.
	12	0600.1018	Terminal do Cabo Gás e Força Gas and Power Cable Terminal	
	13	0801.2085	Conector Macho TIG 12,80mm c/Entrada do Gás TIG Male Connector w/ 12,80mm Gas Input	
	14	0801.2090	Conector Macho TIG 9,00mm c/Entrada do Gás TIG Male Connector w/ 9,00mm Gas Input	
	16	0600.1093	Mangueira de Entrada do Gás Input Hose Gas	0,40m 3/16"
		0600.1669		0,40m 5/16"
		0600.1094		0,40m 3/16"
	17	0600.1023	Acionamento da Tocha Torch Trigger	
	18	0600.1022	Cabo de Acionamento 4m Trigger Cable 4m	
	19	0600.1060	Capa Protetora dos Cabos 3m Cable Protection Cover 3m	
	20	4002.1013	Anel O'Ring O-Ring	
	16	0600.1560	Isolação Termo Retrátil do Terminal Thermo Retractable Insulation	p/ metro